

# ON Semiconductor

## Is Now

# onsemi™

To learn more about onsemi™, please visit our website at  
[www.onsemi.com](http://www.onsemi.com)

---

**onsemi** and **onsemi** and other names, marks, and brands are registered and/or common law trademarks of Semiconductor Components Industries, LLC dba "**onsemi**" or its affiliates and/or subsidiaries in the United States and/or other countries. **onsemi** owns the rights to a number of patents, trademarks, copyrights, trade secrets, and other intellectual property. A listing of **onsemi** product/patent coverage may be accessed at [www.onsemi.com/site/pdf/Patent-Marking.pdf](http://www.onsemi.com/site/pdf/Patent-Marking.pdf). **onsemi** reserves the right to make changes at any time to any products or information herein, without notice. The information herein is provided "as-is" and **onsemi** makes no warranty, representation or guarantee regarding the accuracy of the information, product features, availability, functionality, or suitability of its products for any particular purpose, nor does **onsemi** assume any liability arising out of the application or use of any product or circuit, and specifically disclaims any and all liability, including without limitation special, consequential or incidental damages. Buyer is responsible for its products and applications using **onsemi** products, including compliance with all laws, regulations and safety requirements or standards, regardless of any support or applications information provided by **onsemi**. "Typical" parameters which may be provided in **onsemi** data sheets and/or specifications can and do vary in different applications and actual performance may vary over time. All operating parameters, including "Typicals" must be validated for each customer application by customer's technical experts. **onsemi** does not convey any license under any of its intellectual property rights nor the rights of others. **onsemi** products are not designed, intended, or authorized for use as a critical component in life support systems or any FDA Class 3 medical devices or medical devices with a same or similar classification in a foreign jurisdiction or any devices intended for implantation in the human body. Should Buyer purchase or use **onsemi** products for any such unintended or unauthorized application, Buyer shall indemnify and hold **onsemi** and its officers, employees, subsidiaries, affiliates, and distributors harmless against all claims, costs, damages, and expenses, and reasonable attorney fees arising out of, directly or indirectly, any claim of personal injury or death associated with such unintended or unauthorized use, even if such claim alleges that **onsemi** was negligent regarding the design or manufacture of the part. **onsemi** is an Equal Opportunity/Affirmative Action Employer. This literature is subject to all applicable copyright laws and is not for resale in any manner. Other names and brands may be claimed as the property of others.

## ThermalTrak™ Audio Output Transistors

Prepared by: Mark Busier  
ON Semiconductor



**ON Semiconductor®**

<http://onsemi.com>

### APPLICATION NOTE

One of the major design concerns in the output section of a typical class AB audio amplifier is output bias and stability over the operating temperature range. In the past, this was typically accomplished through the use of a single bias transistor mounted on the amplifier's heatsink in close proximity to the output devices. When this is done, there is a period of time that must pass before thermal equilibrium or stability has been reached. This period may last as long as 30 minutes. This is known as warmup time. Most designers have to slightly underbias the amplifier output devices so that thermal runaway does not occur. These tradeoffs take away from true high fidelity performance of the amplifier.

The ThermalTrak devices were developed so the design engineer could more accurately control the bias of the output stage of an audio amplifier. The most efficient and straightforward solution to the problem is to incorporate a temperature sensing device into the output transistor. This will improve amplifier performance and offer instant bias regulation in the power output stage.

Another benefit of integrating the diode with the power transistor is that actual real time protection from thermal runaway can be implemented into an audio output section through temperature sensing between the active elements.

Each of the ThermalTrak audio output devices incorporates Ultrafast diode technology as the temperature sensing device along with the audio output transistor.

Although many circuit variations exist, the amplifier circuit in Figure 1 is typical of most used in the industry today. Modifications were made to improve stability and performance with low impedance loads.

The bias circuit consists of a small signal transistor (TO-92) mounted on the heat sink between the (TO-220) power output drivers. Bias stability in this design requires that the bias level be set to a point at which thermal runaway does not occur, yet high enough to prohibit crossover distortion. In this design, the actual voltage drop across the bias transistor was set to 3.2 volts between emitter and collector. Any more bias voltage than that and a small amount of thermal runaway would occur when the amplifier is driven hard into a low impedance load.

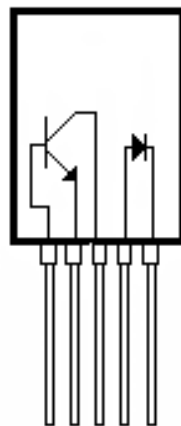

ThermalTrak™ Device TO-264 Package

# AND8196/D

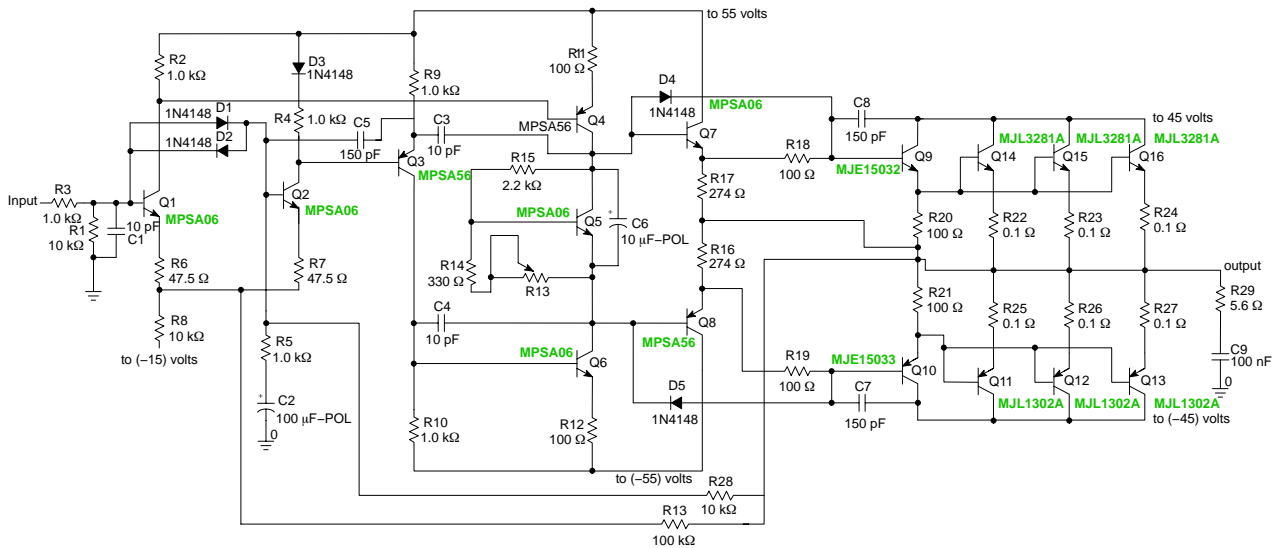

Figure 1.

The thermal runaway is caused by a small amount of thermal lag in the heatsink. In order to improve the small signal distortion of the amplifier due to this thermal lag slightly more bias is required. A trim potentiometer, as shown in Figure 1, is used with an active bias transistor to facilitate biasing.

With minimal emitter resistors, (0.1 Ω) on the output devices, this biasing becomes very delicate and time consuming in a production environment. Many circuit variations have been implemented to help reduce this effect. Each of them incurs an increase in the system cost.

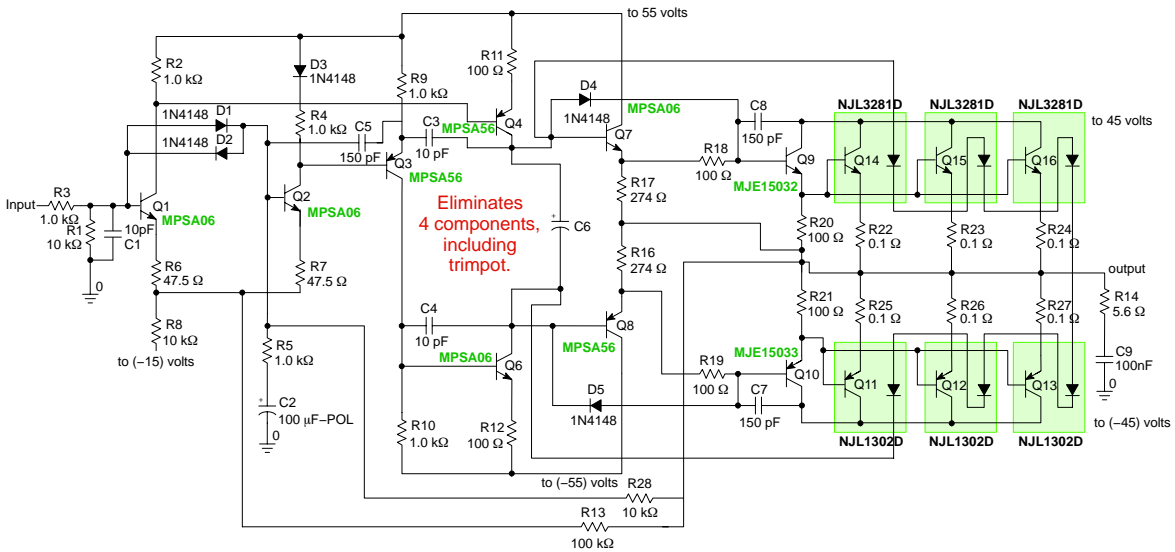

Figure 2.

By thermally integrating bias diodes into the output transistors, the actual die temperature can be precisely monitored in real-time. When this is done, the bias is now controlled internally and changes are compensated for on a real time basis. The result is an instantly trimmed bias current that does not allow any thermal runaway or thermal lag due to the mass of the heatsink. Another benefit of the modified circuit is the fact that it can be implemented without the use of a bias trimming potentiometer. This also eliminates a production step and guarantees that a quiescent bias point has been reached.

In Figure 2, the active bias transistor and all the passive components have been removed and replaced by the integrated power output transistor and diode solution (ThermalTrak). The result is a stabilized bias current providing a very accurate quiescent current that adjusts to loading and signal levels almost instantaneously. Distortion levels at lower output voltages will improve dramatically, as will full power THD performance. The noise floor of the amplifier will also improve through the elimination of the oscillation at the zero volt crossing caused by the slightly underbiased condition created by the original circuitry.

Amplifier settling time and bias stabilization will also demonstrate improvement with a slightly lower output impedance to work with. The amplifier will also work better over temperature since the bias current is now monitored by the actual die temperature within the output transistors instead of using the heatsink temperature. These improvements are shown in Figure 3.

An Audio Precision analyzer was used to measure the THD performance. With bias diodes integrated into the output transistors, the new quiescent bias voltage has been raised to 3.4 volts and lower distortion performance is achieved without any thermal lag issues. The amplifier circuit also is completely stable with a 2 Ω load without any bias current creep typically caused by temperature differences between power components or thermal shock.

As shown in the distortion curves in Figure 3, a large improvement in distortion performance is achieved using the ThermalTrak transistor technology. Most of the improvements are in the region of lower power output

voltages where the majority of the lower level musical content exists. It should also be noted that bias control is active over a much wider range. There is virtually no warmup time.

Along with bias control, there are a number of other applications that can be derived from this type of component configuration such as individual driver control for current sharing in the output devices, or temperature sensing for a protection circuit.

In this application we have shown how to increase the reliability of an audio power amplifier and improve performance where it counts the most, the ability to build something without the need for additional manual adjustments to make it function correctly. We have also reduced manufacturing cost and eliminated the thermal lag associated with big bulky heatsinks. Along with this, also note that a bias adjustment will not be required for a reasonable performance power amplifier.

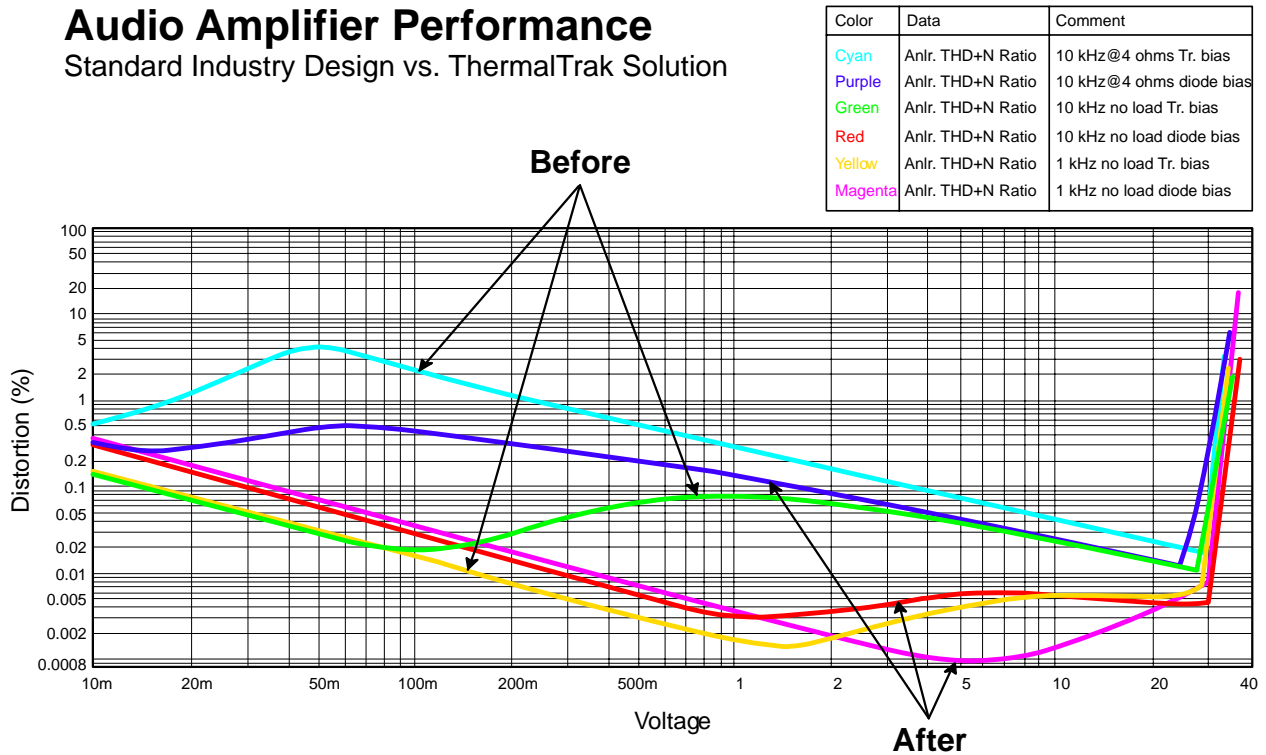



Figure 3. Load Conditions: 4 Ω non-inductive resistor for sweep 1. No load for sweeps 2 and 3.

ThermalTrak is a trademark of Semiconductor Components Industries, LLC.

**ON Semiconductor** and  are registered trademarks of Semiconductor Components Industries, LLC (SCILLC). SCILLC reserves the right to make changes without further notice to any products herein. SCILLC makes no warranty, representation or guarantee regarding the suitability of its products for any particular purpose, nor does SCILLC assume any liability arising out of the application or use of any product or circuit, and specifically disclaims any and all liability, including without limitation special, consequential or incidental damages. "Typical" parameters which may be provided in SCILLC data sheets and/or specifications can and do vary in different applications and actual performance may vary over time. All operating parameters, including "Typicals" must be validated for each customer application by customer's technical experts. SCILLC does not convey any license under its patent rights nor the rights of others. SCILLC products are not designed, intended, or authorized for use as components in systems intended for surgical implant into the body, or other applications intended to support or sustain life, or for any other application in which the failure of the SCILLC product could create a situation where personal injury or death may occur. Should Buyer purchase or use SCILLC products for any such unintended or unauthorized application, Buyer shall indemnify and hold SCILLC and its officers, employees, subsidiaries, affiliates, and distributors harmless against all claims, costs, damages, and expenses, and reasonable attorney fees arising out of, directly or indirectly, any claim of personal injury or death associated with such unintended or unauthorized use, even if such claim alleges that SCILLC was negligent regarding the design or manufacture of the part. SCILLC is an Equal Opportunity/Affirmative Action Employer. This literature is subject to all applicable copyright laws and is not for resale in any manner.

## PUBLICATION ORDERING INFORMATION

### LITERATURE FULFILLMENT:

Literature Distribution Center for ON Semiconductor  
P.O. Box 61312, Phoenix, Arizona 85082-1312 USA  
**Phone:** 480-829-7710 or 800-344-3860 Toll Free USA/Canada  
**Fax:** 480-829-7709 or 800-344-3867 Toll Free USA/Canada  
**Email:** [orderlit@onsemi.com](mailto:orderlit@onsemi.com)

**N. American Technical Support:** 800-282-9855 Toll Free  
USA/Canada

**Japan:** ON Semiconductor, Japan Customer Focus Center  
2-9-1 Kamimeguro, Meguro-ku, Tokyo, Japan 153-0051  
**Phone:** 81-3-5773-3850

**ON Semiconductor Website:** <http://onsemi.com>

**Order Literature:** <http://www.onsemi.com/litorder>

For additional information, please contact your  
local Sales Representative.