

NCV7685I2CV1GEVB

NCV7685 Twelve Channels LED Linear Current Driver with I²C Interface Evaluation Board User's Manual

Introduction

The evaluation board demonstrates the Rear Combination Lamp Application with the NCV7685 LED linear current driver. On-board buck converter creates constant voltage of 7.0 V on the top of the LEDs to have lower power dissipation on the device itself. The board contains up to three LEDs in a series for each twelve channels. The amber color of the LEDs emulates TAIL/STOP functionality. The board contain jumper switch where demonstration mode or evaluation mode can be selected. Several different animations can be played without need of computer connection in demonstration mode.

NCV7685 has several kinds of the fault detections. Fault detection can be emulated by shorting or opening on-board jumpers. The indication LEDs can inform users about diagnostic and the status of the supplies. More faults and statuses can be read out using PC control software in the evaluation mode configuration.

Multiple evaluation boards can be interconnected using I²C communication + DIAG interface. Because default address is the same for every board, the I²C address has to be set independently.

Evaluation Board Features

- Wide Range of Supply Voltage: 8 to 18 V
- 3 × 12 Amber LEDs
- V_{STRING} Voltage 7.0 V
- V_{DD} Voltage 5.0 V
- Nominal LED String Current
 - ◆ 10 mA – Nominal Current
 - ◆ 50 mA – High Current Set by Jumper
- Input CONF1 and CONF2 Switch Selector
- LED Open-loads, I_{SET} Short to Ground Emulation Jumpers
- Loss of V_{DD} and loss of VS Emulation Jumper
- Thermal Shutdown
- Global Output Enable Jumper
- External I²C Header Connector
- Positions for Optional EMC Capacitors
- Backward PCB Compatibility with the NCV7684 Device



ON Semiconductor®

www.onsemi.com

EVAL BOAR USER'S MANUAL

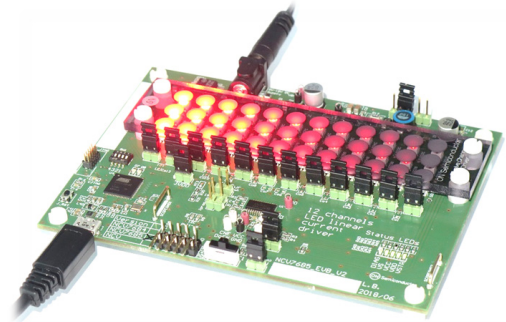

Figure 1. NCV7685I2CV1GEVB

NCV7685I2CV1GEVB

Table 1. ABSOLUTE MAXIMUM RATINGS

Rating	Value	Unit
Supply Voltage (V_{BAT})	-28 to +28	V
LED Strings Current	720	mA
Junction Temperature (NCV7685, NCV8853)	-40 to +150	°C
Junction Temperature (Advanced Power TOPLED OSRAM LED)	-40 to +125	°C
Ambient Temperature	-40 to +105	°C

Stresses exceeding those listed in the Maximum Ratings table may damage the device. If any of these limits are exceeded, device functionality should not be assumed, damage may occur and reliability may be affected.

Table 2. RECOMMENDED OPERATING CONDITIONS

Rating	Value	Unit
Supply Voltage (V_{BAT})	8 to 18	V
Rated LED String Current	10/50	mA
Fault Mode – Board Consumption ($V_S = 13.5$ V, AutoR = 1, MCU disconnected, status LEDs powered)	≈9	mA
Auxiliary Circuits Consumption (DC/DC, LDO, MCU, pull-ups, ...)	≈68	mA
Ambient Temperature (for rated LED current)	-40 to +105	°C

Functional operation above the stresses listed in the Recommended Operating Ranges is not implied. Extended exposure to stresses beyond the Recommended Operating Ranges limits may affect device reliability.

Table 3. INTERFACE FUNCTION DESCRIPTION

Connector Name	Connector Type	Description/Function
Supply	DC POWER, 2.1MM	Input supply connector, DC 8–18 V.
$J_{DCShort}$	1x2 Header	Bypass DC/DC converter, apply supply voltage to V_{STRING} .
J_{UV}	1x2 Header	Decrease V_{STRING} voltage from 7 V to 6 V.
J_{VS}	1x2 Header	VS supply to the NCV7685.
J_{VDD}	1x2 Header	VDD supply to the NCV7685.
J_{OEN}	1x2 Header	Disconnect J_{OEN} during startup. To deactivate all outputs, put OEN pin to low, otherwise keep OEN pin high during the normal operation.
J_{HiCur}	1x2 Header	10 mA/50 mA current setting.
OL1 – OL12	1x2 Header	Open Load emulation jumper.
$J_{prog/sh}$	2x2H Header	Emulate short of the I_{SET} pin. (Horizontal position)
$J_{prog/sh}$	2x2V Header	Apply 2.9 V on the I_{SET} pin (for OTP read/write access). (Vertical position)
I2Ca	1x5 Header	Digital supply, I ² C line and Diagnostic connector.
I2Cb	1x5RA Header	Digital supply, I ² C line and Diagnostic connector.
J_{JTAG}	2x5 Header	JTAG programming connector for MCU.
SW1	Switch 4P	Demonstration Mode / Evaluation mode.
J_{RST}	Button	MCU reset button.
SW _{Conf}	Switch	CONF1/CONF2 selector.
V _{BAT} , GN, EN, V _{DD} , CNF, DgEN, V _{CC} , PwG, GND, OEN, DIAG	Test Point	Test points.
ScopeGND1, ScopeGND2	Wire Bridge	Ground wire.
J_{USB}	microUSB	Micro USB – PC connector.
NT3	Jumper Strap	Powering resistor divider for 2.9 V supply for OTP access.
NT4	Jumper Strap	Enabling of DC/DC converter.
NT5	Jumper Strap	Powering digital supply for MCU.

Getting Started

The evaluation board is supplied through a standard 5.5 × 2.1 mm DC connector. Supply voltage range has to be from 8 to 18 V. Below 8 V the current through the LEDs starts decreasing. For the supply voltage above 18 V, the board temperature can be the limitation. Jumpers J_{VS}, J_{VDD} and J_{OEN} should be connected for normal operation.

The NCV7685 evaluation boards can work either in *Demonstration mode*, where animation is performed in the loop or in *Evaluation mode* where user can evaluate all functions using computer control program.

For the *Evaluation mode* the EVB board has to be connected to the PC and controlled using SW program. To activate the Evaluation mode the SW1[1] switch has to be configured that pin 1 is in OFF position, other pins doesn't care. Resetting the MCU using J_RST button is highly recommended before connection to the PC software. The Software description is in the Page 7.

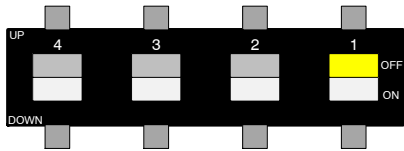

Figure 2. SW1 Configuration for Evaluation Mode

For the *Demonstration mode* the VS, VDD and Output ENable jumpers (J_{VS}, J_{VDD} and J_{OEN}) has to be closed. The MCU performs the animation effects in the loop in the standalone way without need of PC.

One of the eight different animation effects can be selected by SW1[4:2]. Activation of the Demonstration mode is done by switching SW1[1] to ON position.

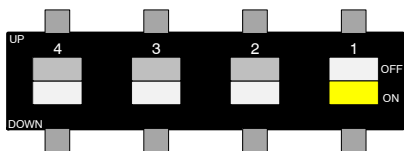

Figure 3. SW1 Configuration for Demonstration Mode

The status of the SW_x switch is read at the end of each animation. If the animation has to be started from the beginning, or different mode has to be set during started

animation, the reset button J_RST will change the mode immediately. The list of all animation is shown in Figure 4.

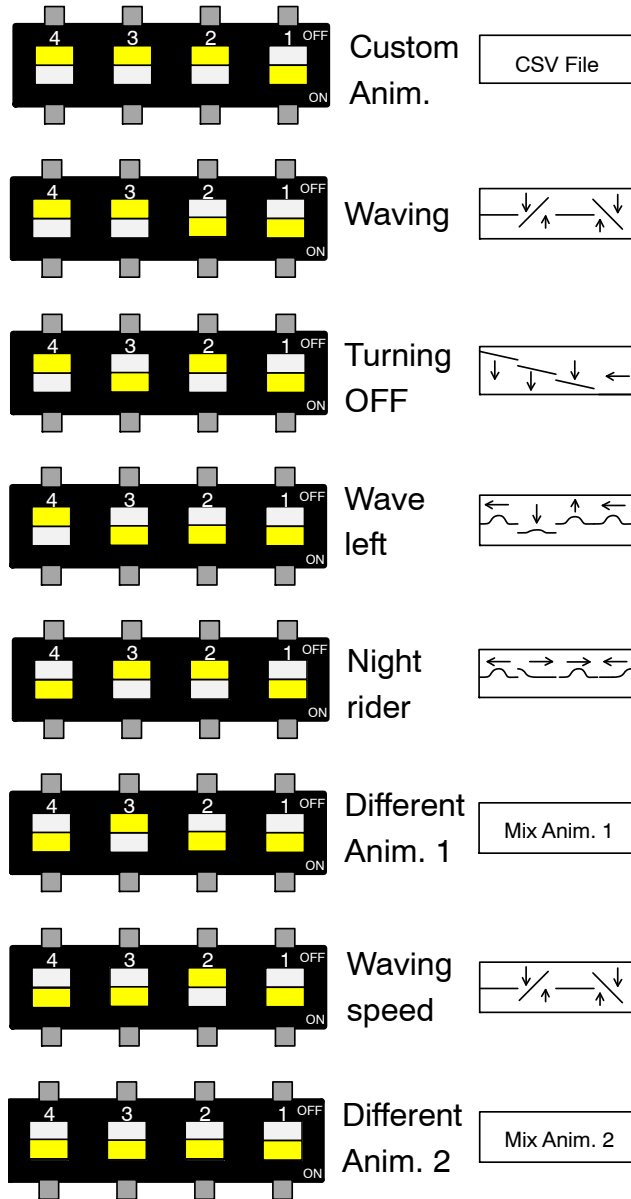

Figure 4. SW1 Configuration for Different Animation Selection

NCV7685I2CV1GEVB

The LED current which is driven by NCV7685 can be changed replacing R1 and R2 resistors using following formula:

$$I_{OUTx} = \frac{K \cdot 1 V}{R_{SET}} = \frac{100 \cdot 1}{2000} = 0.05 [A] \quad (\text{eq. 1})$$

$$R_{SET} = R1 + R2 [\Omega] \quad (\text{eq. 2})$$

Where:

- I_{OUTx} – OUTx LED channel current flow
- K – I_{SET} factor with value of 100
- R_{SET} – Total I_{SET} Resistance
- $R1$ – “Shielded” Resistor
- $R2$ – “Adjustment” Resistor

The LED current flow is set to 10 mA per each activated channel by default. The current can be increased by shorting JHiCur header by jumper up to 50 mA per active channel.

To ensure stable low voltage drop on the output pins, using DC/DC converter is highly recommended. The V_{STRING} voltage is provided by buck DC/DC converter which is configured to have output voltage at 7.0 V. If needed the V_{STRING} voltage can be adjusted by replacing the R_A and R_B resistors.

The formula for V_{STRING} voltage using NCV8853 converter is:

$$V_{STRING} = 0.8 \cdot \frac{R_A + R_B}{R_B} \quad (\text{eq. 3})$$

The DC/DC converter can be easily bypassed by shorting jumper $J_{DCshort}$. After bypassing the DC/DC converter, the V_{STRING} voltage will be powered directly from the V_{BAT} . Applying too high V_{BAT} voltage with combination with high current setting can cause high thermal dissipation and device will go into thermal shutdown mode.

Shorting under voltage jumper J_{UV} can emulate under voltage on the top of the LEDs (V_{STRING}) which will be 1.0 V less then nominal. During the under voltage the output voltage of the DIAGEN resistor divider will be below threshold and this can be detected by the NCV7685 device. This will lead to disable diagnostic detection. The DIAGEN status flag can be read in I²C mode.

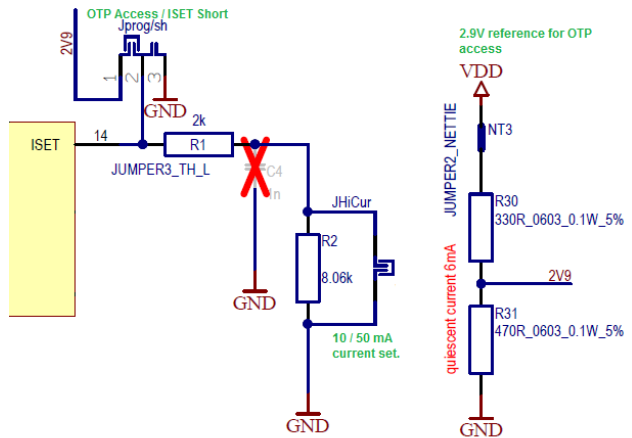

Figure 5. Schematic of the ISET Connection

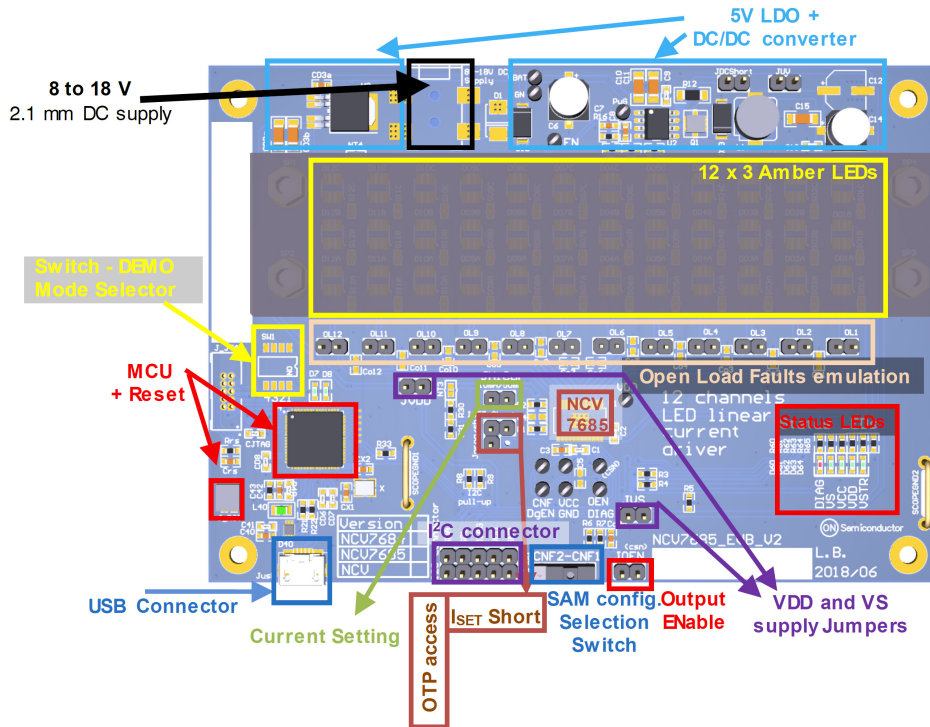

Figure 6. NCV7685 Twelve Channel LED Linear Current Driver Board Picture

NCV7685I2CV1GEVB

Modules Control Strategy

The board is designed to operate primary with DC/DC converter which creates stable voltage on the V_{STRING} supply line. The high voltage drop on the OUTx pins in combination with higher currents can cause huge power dissipation. To have reasonable power dissipation, the

voltage on the OUTx pin in ON state should be limited to max 1.0 V during high current flow. Forward voltage of the LEDs depends on the number of connected LED string can be from 2.0 V to 6.0 V. The NCV7685 can operate in I²C or in standalone mode.

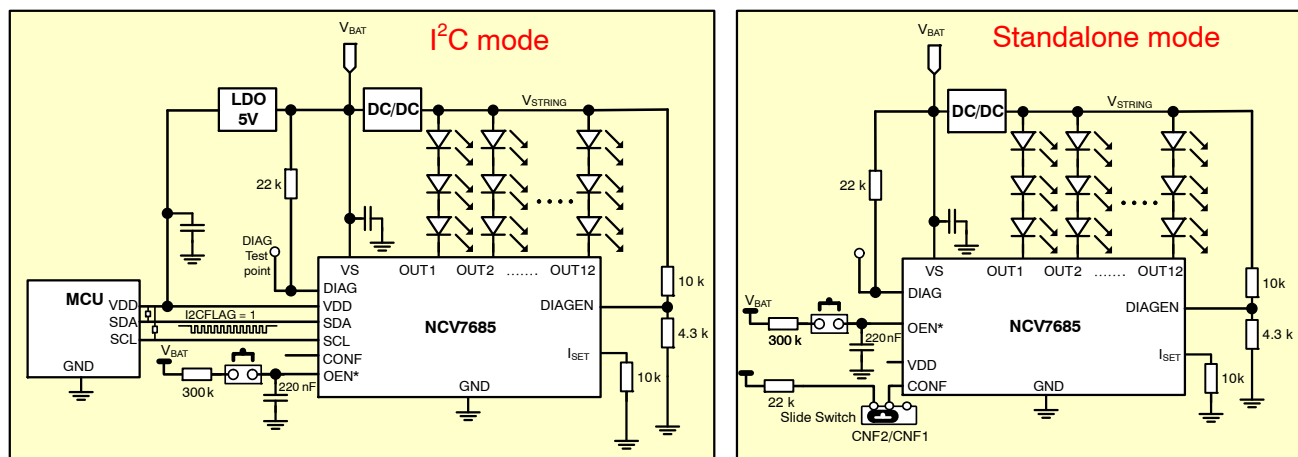

NOTE: *The OEN voltage has to be lower than 5 mV/10 μ s during the startup according to the application note AND90032/D [4] otherwise wrong startup may occur.

It is necessary to power-up the board with J_{OEN} jumper disconnected, or to carefully verify the voltage on the OEN pin during the startup. Some of the EVB boards may be still assembled with lower RC filter, please review the R7 and Coen value before using this EVB board. If voltage on the OEN pin is not lower than 5 mV/10 μ s, then the R7 has to be changed from original 22 k Ω to 300 k Ω and Coen from original 1 nF to 220 nF.

Figure 7. Simplified Options How to Control Current Flow by the LEDs

Standalone Mode

Device enters into standalone mode in following cases:

- Immediately after startup
- When V_{DD} voltage falls down below undervoltage threshold
- When I2CFLAG is cleared down

The output channel configuration and diagnostic behavior is read out from OTPs. Two possible output channel configurations can be set, depending on the CONF pin setting. The output channels can be either turned ON or OFF.

I²C Mode

To enter into I²C mode the V_{DD} supply is needed. Device will enter into I²C mode as soon as the I2CFLAG is set.

Extended functions can be controlled or read in I²C mode:

- PWM control
- OTP programming
- Diagnostic control
- ON/OFF activation of the individual channels
- Reading status bits
- Reading extended Fault statuses

How to control the I²C registers is described in the [NCV7685 datasheet](#) or in the NCV7685 I²C Programming Guide [application note](#).

I_{SET} Capability

The output current of the active channels is defined by external resistor between I_{SET} and ground.

The default configuration of the I_{SET} connection is described in Figure 5. If the EMC improvement is needed, the simple modification with external C4 capacitor can be applied.

Horizontal jumper connection J_{prog/sh} can emulate short I_{SET} to ground. During normal operation this jumper is in open position.

The output LED current setting can be changed by shorting/opening jumper J_{HiCur}. When the jumper J_{HiCur} is open, the output current is only 10 mA per channel. Increase output current can be achieved by shorting the terminals. The current can be increased up to 50 mA per one channel.

The access to the OTP registers is allowed only when voltage between 2.5 V and 3.3 V is applied to the I_{SET} pin. The resistor divider R30 and R31 creates 2.9 V voltage which can be applied to the I_{SET} pin by vertical jumper connection of the J_{prog/sh} header. The closing position for OTP programming is shown in Figure 8.

Power Dissipation

The main source of power dissipation is device itself and the on board LEDs. Total power dissipation of all 36 Red LEDs which are operated at 50 mA is 3.37 W.

The thermal resistance of the SSOP24 package with expose pad mounted on this evaluation board is around 42.6°C/W. The thermal shutdown was achieved at ambient temperature when OUTx voltage was higher than 5.87 V for 50 mA per each output. Maximum power dissipation on the linear driver which can NCV7685 EVB board handle is 3.52 W at ambient temperature. Using DC/DC converter with voltage drop of 1.0 V on the activated outputs will decrease the power dissipation on the linear driver significantly.

Thermal warning flag is activated with junction temperature above 140°C.

The formula to calculate thermal heating is following:

$$\begin{aligned}\Delta T_J &= R_{\theta JA} \cdot P \text{ [}^\circ\text{C]} \\ \Delta T_J &= 42.6 \cdot 0.8^\circ\text{C} \quad (\text{eq. 4}) \\ \Delta T_J &= 34.1^\circ\text{C}\end{aligned}$$

The junction temperature will raise about 34.1°C above ambient temperature when the overall power dissipation on the device will be 0.8 W.

The worst case power dissipation is calculated as:

$$\begin{aligned}P &= N \cdot V_{OUTx} \cdot I_{OUTx} + V_{BATMax} \cdot I_{VS} + I_{VCC} \cdot (V_{BATMax} - V_{CC}) \\ P &= 12 \cdot 1.0 \cdot 0.05 + 18.0 \cdot 0.01 + 0.001 \cdot (18.0 - 3.3) \\ P &= 0.8 \text{ W} \quad (\text{eq. 5})\end{aligned}$$

Where:

- ΔT_J – Increase temperature of the device
- $R_{\theta JA}$ – Thermal resistance Junction – Ambient
- P – Power dissipation of the NCV7685
- V_{OUTx} – Voltage drop on the OUTx pin
- I_{OUTx} – LED Output current
- N – Number of channels
- V_{BATMax} – Maximum battery voltage
- I_{VS} – NCV7685 device current consumption
- V_{CC} – Output reference voltage
- I_{VCC} – Output reference current

Diagnostic and Fault Detection

The NCV7685 can detect several status flags and faults. The faults may be reported to the DIAG pin and reported into registers. Open Load diagnostic is enabled only if DIAGEN voltage is higher than DIAGEN enable threshold (2.0 V typ.) simultaneously the diagnostic bits have to be appropriate configured. In case of slow ramp-up of the VSTRING voltage the diagnostic is disabled to not report false open loads using the DIAGEN circuitry. Other faults and statuses are reported in the I2C_STATUS register. How a fault is reported and processed depends on the configuration of the OTP or I²C Registers in combination with DIAGEN signal.

Setting the *AutoR (I2CAutoR) bit* will cause switching OFF all channels when at least one fault is present. Open Drain DIAG signal is pulled low to indicate the fault. If external fault is present, DIAG pin is pulled low externally, it will lead to switching OFF all channels. As soon as the fault is recovered, the LED driver returns to normal operation.

If *DetOnly (I2CDOOnly) is set*, Open Load diagnostic is performed. When a fault is detected, the DIAG pin is set without taking any action on the current regulation. If Diag pin is pulled low externally, there is no action on the current regulation. The status of the Open Loads can be read in the I²C registers.

In case of *none of the bits are set*, no Open Load diagnostic is performed and reported neither in I²C register nor on the DIAG pin.

If *both flag bits (AutoR and DetOnly) are set*, the previous setting register is taken into account.

DIAGEN voltage is sensing via 10 kΩ and 4.3 kΩ resistor divider the VSTRING voltage. During the normal operation while VSTRING = 7.0 V, the typical voltage on the DIAG pin is 2.105 V which is above the threshold. If the voltage on VSTRING drops down, the diagnostic will be disabled.

Under voltage on the VSTRING can be emulated by shorting JUV jumper. It will lead to decrease VSTRING to 6.0 V. The DIAGEN voltage will be below the threshold with value 1.8 V. The voltage status can be verified by reading the status register.

NCV7685I2CV1GEVB

Table 4. FAULTS BEHAVIOR IN CASE OF OPEN LOAD ON SOME CHANNELS (OL), EXTERNAL DIAG ERROR, OR I_{SET} SHORT

AutoR or (I2CautoR)	DetOnly or (I2CdOnly)	DIAGEN	Fault Type	Remaining LEDs during the Error	DIAG Pin	DIAG err FLAG	OL FLAG	SC FLAG
0	0	> 2 V	OL	ON	not active	0	0	0
0	1	> 2 V	OL	ON	Fault	0	1	0
1	0	> 2 V	OL	OFF	Fault	0	1	0
1	1	> 2 V	OL	previous setting	prev. set	0	prev. set	0
x	x	< 2 V	OL	ON	not active	0	?(*)	0
x	x	< 2 V	DIAG err	ON	External	1	0	0
0	0	> 2 V	DIAG err	ON	External	1	0	0
0	1	> 2 V	DIAG err	ON	External	1	0	0
1	0	> 2 V	DIAG err	OFF	External	1	0	0
1	1	> 2 V	DIAG err	previous setting	External	1	0	0
x	x	x	I _{SET} short	OFF	Fault	0	0	1

?(*) NCV7685 maintain its last value

PC Control Software

On-board *Microcontroller* together with PC software allows control the NCV7685 device using I²C bus. All statuses can be read and they are easily visible in the control panel. (Figure 9). The register names and individual bits in the control panel correspond to the registers which are described in the datasheet. Every register can be read or write by appropriate button. Please note that for access to *Hard Coding Registers* and OTP registers the I_{SET} pin has to be put in range of $2.5\text{ V} \leq I_{SET} \leq 3.3\text{ V}$. Figure 8 show where to connect jumper to apply 2.9 V on the I_{SET} pin.

The evaluation board can be also controlled by sending specific commands to MCU using serial port terminal program.

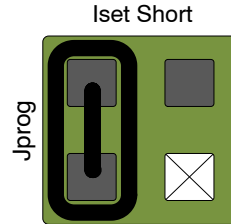

Figure 8. I_{SET} Jumper Connection to Have Access to the OTP and Hard Coding Registers

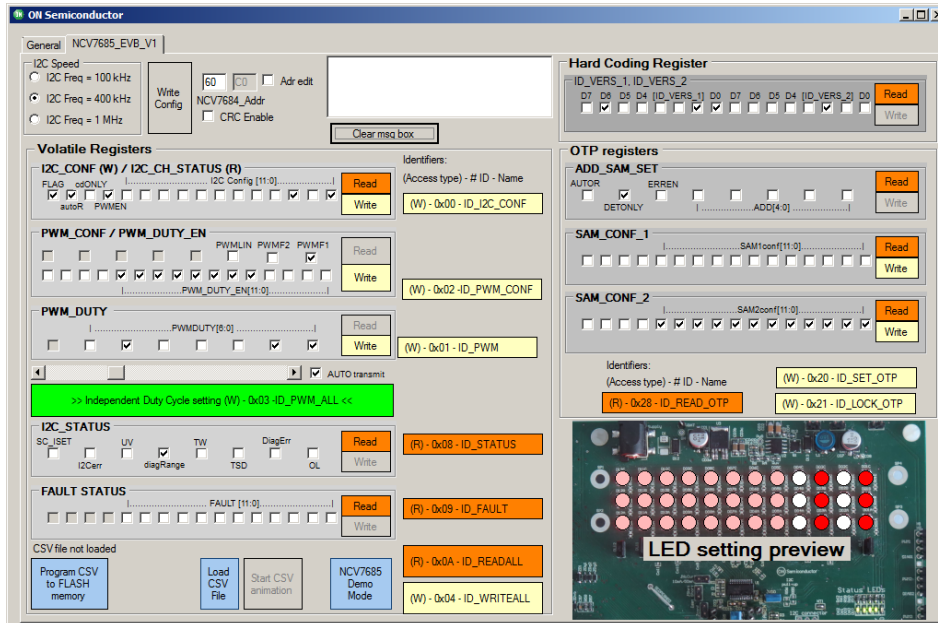

Figure 9. PC Control Panel for NCV7685_EVB_V1

NCV7685I2CV1GEVB

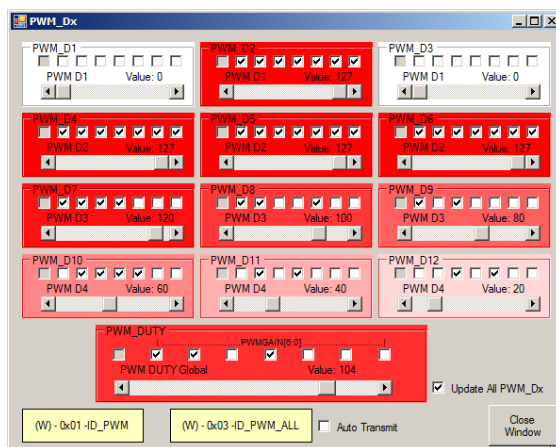

Figure 10. Individual PWM Duty Cycle Setting

PC Control Software Getting Started

1. Disconnect all jumpers except J_{VS} and J_{VDD} .
2. Set first pin of the SW1 switch to the OFF position (Figure 2).
3. Supply the board using 12 V, 1 A power supply.
4. Connect J_{OEN} jumper.
5. Connect the EVB board and PC using micro USB cable by J_{USB} connector.
6. Push J_{RST} reset button for 1 s.
7. Install USB drivers and PC software.
(only for first time)
8. Open NCV7685_EVB_V1 PC SW.
9. Click on “Update Port List”.
10. Choose appropriate COM port. (If there are already multiple COM ports available, then disconnect the USB cable, check the available COM ports then connect USB cable and the new COM port belongs to the NCV7685_EVB_V1 board.)
11. Click on the “Open Port”.
12. The connection can be verified by clicking on the “Get Version” button where MCU should response the actual FW version similarly as follows:

```
tx> get ver
rx> ver=NCV7685_rev_1 2018-03-05
```
13. In the “NCV7685_EVB_V1” tab the MCU has to be configured for I²C functionality by clicking on the “Write Config” button.
14. The response from the MCU should be following:

```
tx> set I2C1CONF
tx> set I2C1SPEED=1
rx> I2C1CONF:ok
rx> I2C1SPEED:ok
```
15. To check the functionality, set the registers based on the Figure 11 screenshot. Then click on the “write” buttons: *ID_I2C_CONF*, *ID_PWM_CONF* and *ID_PWM*. The expected output LED intensity is shown in Figure 12.

The Features of the PC Control Software

Independent Duty Cycle Setting

All PWM_Dx registers can be shown in the separate window by clicking on the “>> Independent Duty Cycle setting <<” button. If the “Auto Transmit” check box is set, every change of the scroll bars or the registers bits related to the duty cycle registers will be automatically transmitted.

Animation Demo Mode

The “Automatic Demo ON” button will configure the NCV7685 device for the PWM mode and it will start periodically sending the ID_PMW_ALL messages with the defined animation with time delay ≈ 50 ms between the messages. The NCV7685 device has to have 0x60 I²C address. The animation can be interrupted by clicking on the “Automatic Demo OFF” button.

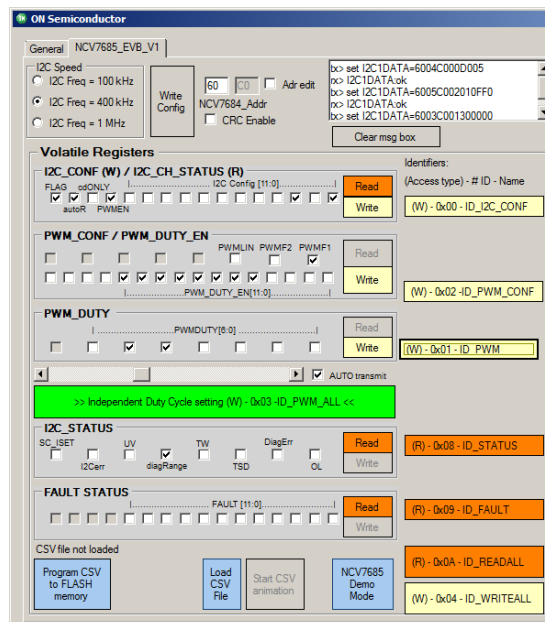

Figure 11. Test Register Setup

NCV7685I2CV1GEVB

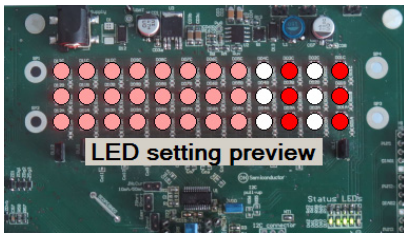

Figure 12. Expected Output Channel Intensity

Output LED Setting Preview

The result of the register setting and the influence on the output LEDs can be displayed in the picture in the right bottom corner. Please note that not all aspects are taken into account like external events, the CONF or OEN

configuration. Also the Linear or Logarithmic translation effects are not considered to be shown.

Custom Animation

The custom animation can be created using the Animation_script_generator_NCV7685.xlsm.

The CSV output file can be either loaded and performed or flashed into FLASH memory of the MCU. The “Load CSV” button load the information about the CSV file and “Start CSV Animation” button will start periodically sending the ID_PWM_ALL messages with the CSV information. Please note that the timing is limited by UART communication speed.

To ensure exact timing, the animation has to be stored inside of the MCU using “Program CSV to FLASH memory” button. It can take longer to program huge CSV files.

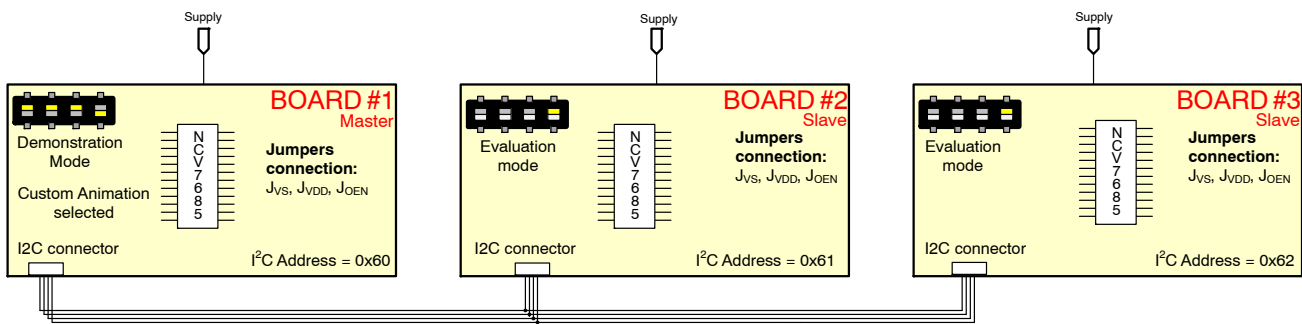

Figure 13. Connecting Multiple Modules into Parallel

Using Multiple Boards Connected into Parallel

Multiple NCV7685 evaluation boards can be connected into parallel using I²C connector which contains I²C lines, VDD supply and DIAG signal. The modules should be configured to the new I²C address first. How to set new I²C address is described in the application note [3].

Daisy chain connection can be used also in Demonstration mode using custom animation. Master board which is configured in Demonstration mode will control remaining modules which are configured in Evaluation mode.

NCV7684 Device Compatibility

The NCV7684 is almost pin to pin compatible with the NCV7685. The board is designed to be used with both silicon versions without need changing of any external component. Because NCV7684 is using for OTP

access the CSN pin instead of I_{SET} the NT3 strap can be disconnected do decrease the power dissipation on the resistor divider. The J_{OEN} jumper will take over the CSN functionality. To activate OTP access, the J_{OEN} (CSN) jumper has to be connected.

The advanced animations are not possible in the demonstration mode with original NCV7685 MCU firmware. In case of using dedicated NCV7684 MCU firmware, the basic animation can be performed.

I²C Communication Protocol Using Embedded MCU

Communication between MCU and PC is done via simple ASCII commands protocol. The commands how to control I²C module, are shown in the Table 5.

NCV7685I2CV1GEVB

Example of the setting FLAG in the I2C_CONF register:

```
set I2C1CONF // I2C module configuration initialization
set I2C1SPEED=1 // 400 kHz speed
set I2C1DATA=6004C000BFFF // Send over I2C four bytes with 0x60 address. Number of
                           // transmitted data = 0x04, Second address = 0xC0
                           // (=RoL(0x60)+WriteFlag), ID = 0x00, I2C_CONF = 0x0BFF
                           // data.
set I2C1DATA=6007C004D000010FFF // Send over I2C seven bytes with 0x60 address. The
                                  // second address is shifted to the left and corresponds to
                                  // the 0xC0. Identifier of the message is 0x04
                                  // (ID_WRITEALL).I2C_CONF is 0xD000. PWM_CONF is 0x01.
                                  // The PWM_DUTY_EN is the 0x0FFF.
```

Read via I²C:

```
get I2C1DATAwr=600205C00A // with address 0x60 write 0x02 bytes and read 0x05
                           // bytes. The first transmitted byte is the second part
                           // address the 0xC0, the second transmitted byte is
                           // identifier for (ID_READALL = 0x0A).
```

Response:

```
I2C1DATAwr=05bfff110400 // received 0x05 bytes. 0xBFFF is I2C_CH_STATUS
                           // register. I2C_STATUS = 0x11 (DiagRange = 1 and
                           // Open Load = 1). FAULT_STATUS = 0x0400. (Eleventh channel
                           // is in Open Load condition)
```

NOTE: Every command has to be confirmed with <cr> character.

NCV7685I2CV1GEVB

Table 5. THE I2C COMMUNICATION PROTOCOL USED BETWEEN MICORCONTROLLER AND PC

I ² C		
	x – is a I ² C Number 1 or 2	X = 1
Configuration	TX: set I2C{x}CONF<cr> RX: I2C{x}CONF:ok<cr> CONF – configures the I ² C pins for I ² C functionality and initialize I ² C peripheral e.g. set I2C1CONF	-
Set I ² C Speed	TX: set I2C{x}SPEED={speed}<cr> RX: I2C{x}SPEED:ok<cr> speed – 0 = 100 kHz; 1 = 400 kHz; 2 = 1 MHz e.g. set I2C2SPEED=1	100 kHz
Data Read/Write	<p>Write</p> TX: set I2C{x}DATA={addr}{count}{data}<cr> RX: I2C{x}DATA:ok<cr> addr – 7 bits device address count – number of data bytes data – is a byte array. Bytes are send from first to last. MSB is written first. e.g. set I2C1DATA=500212AB	-
	<p>Read</p> TX: get I2C{x}DATA={addr}{count}<cr> RX: I2C{x}DATA={count}{data}<cr> addr – 7 bits device address count – number of data bytes data – is a byte array. Bytes are send from first to last. MSB is written first. e.g. get I2C2DATA=5002	
	<p>Write/Read with Repeated Start (Sr)</p> TX: get I2C{x}DATAWR={addr}{count_write} {count_read}{data_write}<cr> RX: I2C{x}DATA={count}{data}<cr> addr – 7 bits device address count – number of data bytes data – is a byte array. Bytes are send from first to last. MSB is written first. e.g. get I2C1DATAWR=50020112AB (returns one data byte)	

NCV7685I2CV1GEVB

EVALUATION BOARD SCHEMATIC

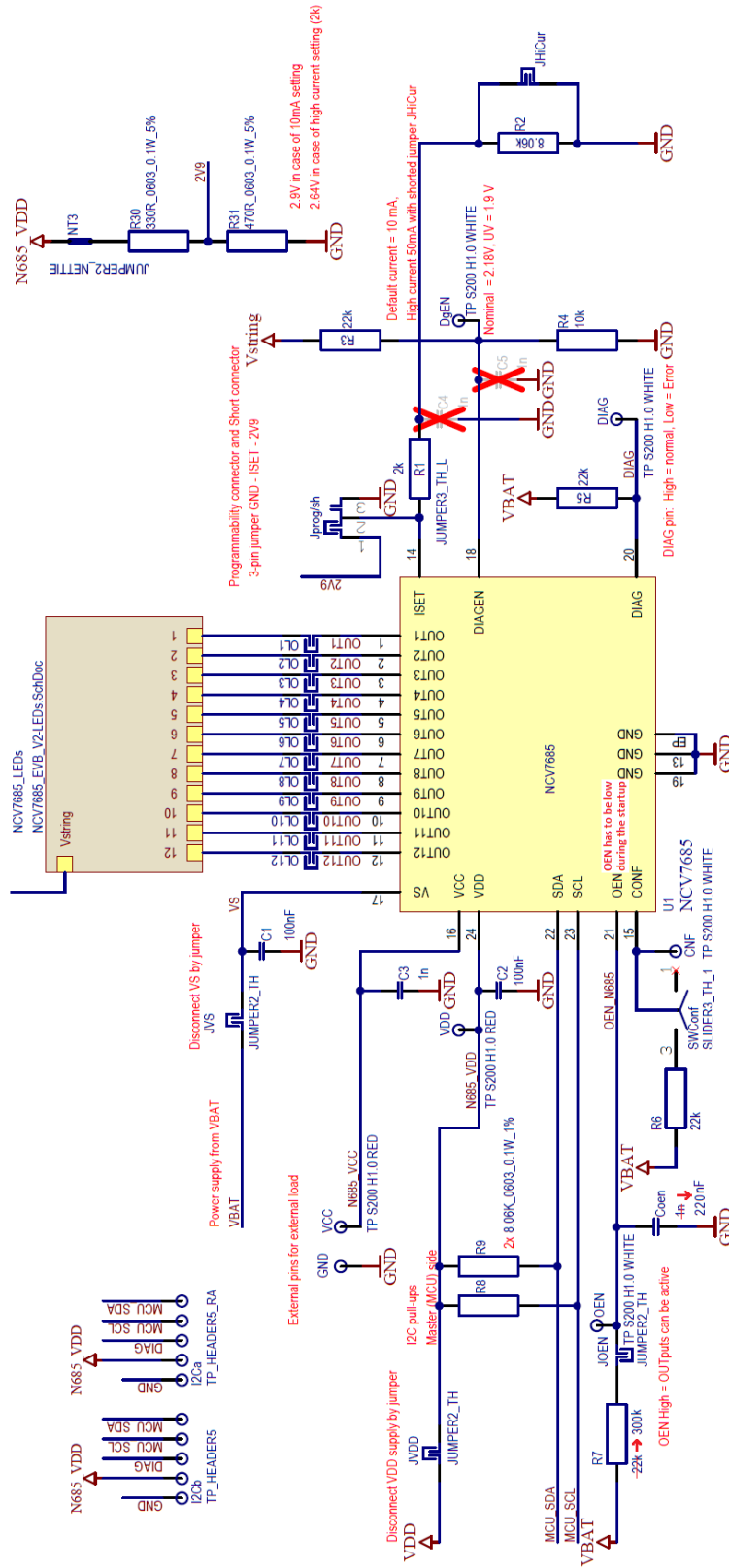

Figure 14. Schematic of the NCV7685 Device Block

NCV7685I2CV1GEVB

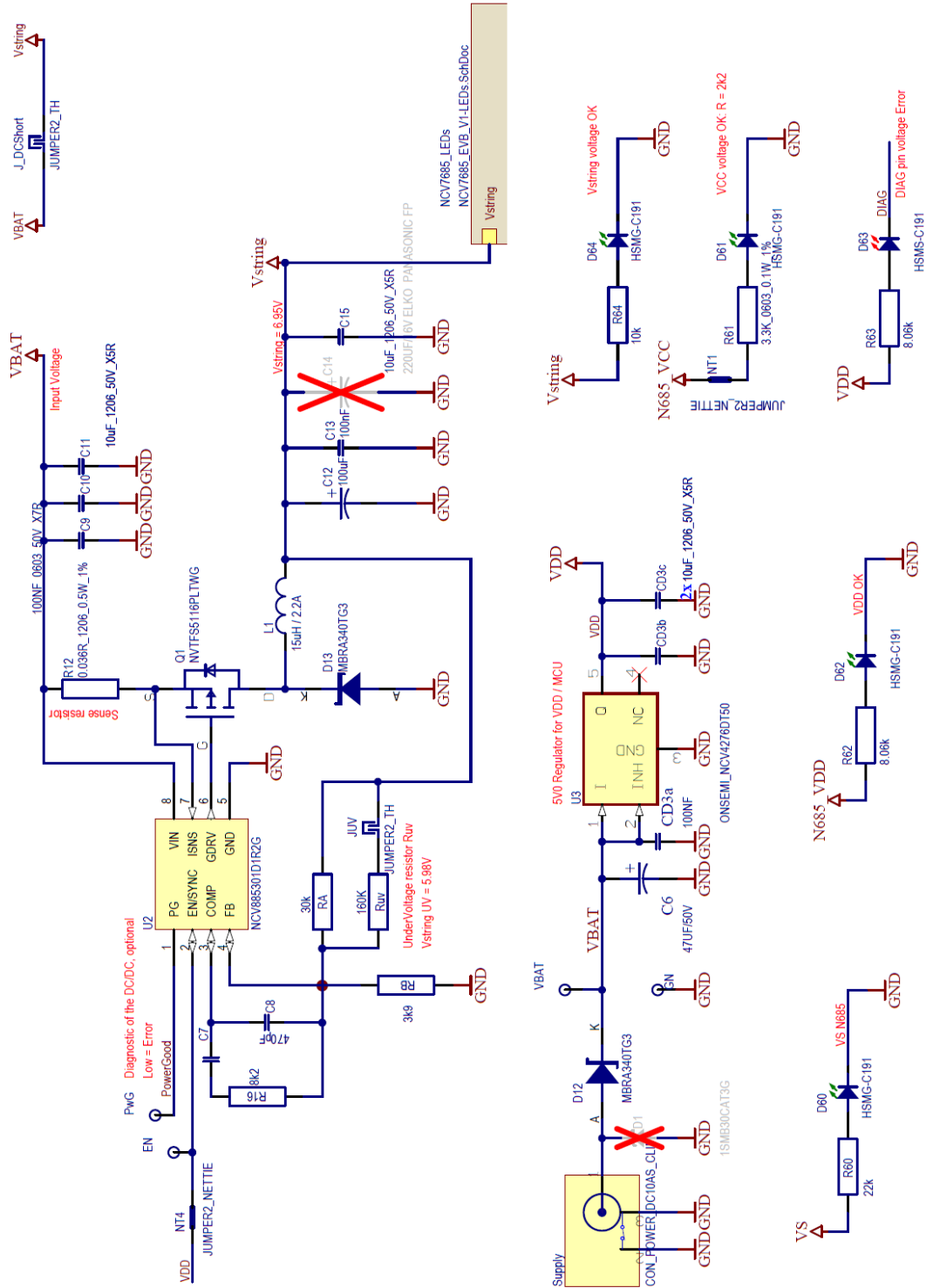

Figure 15. Schematic of the Supply Elements

NCV7685I2CV1GEVB

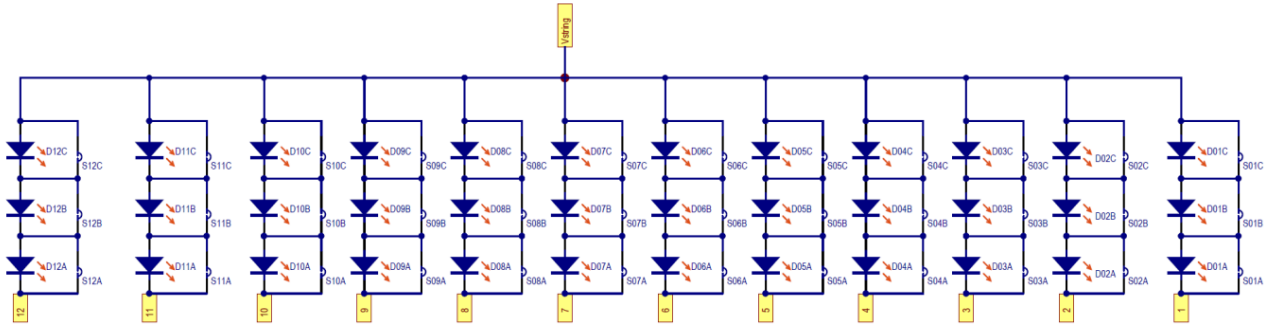

Figure 16. Schematic of the LEDs

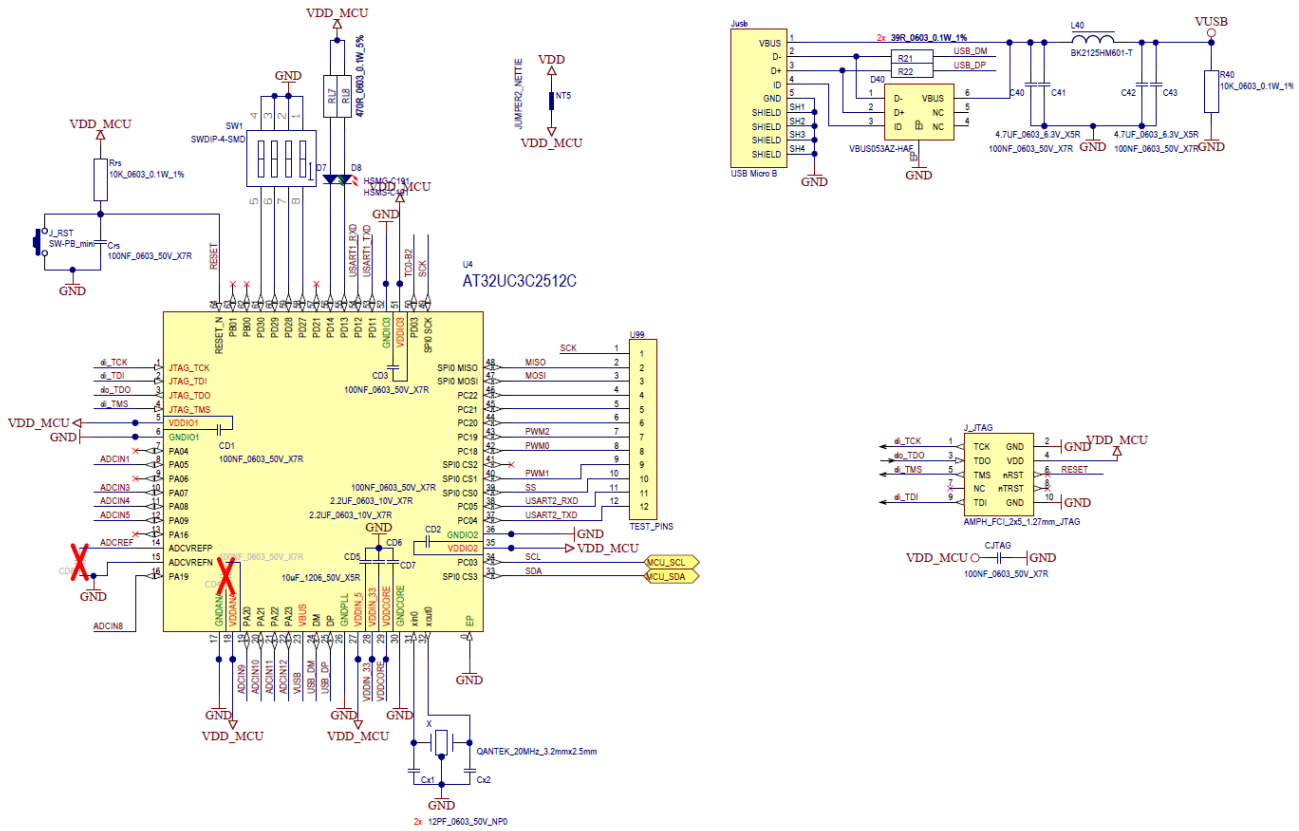

Figure 17. Schematic of the MCU

NCV7685I2CV1GEVB

PCB DRAWINGS – ASSEMBLY

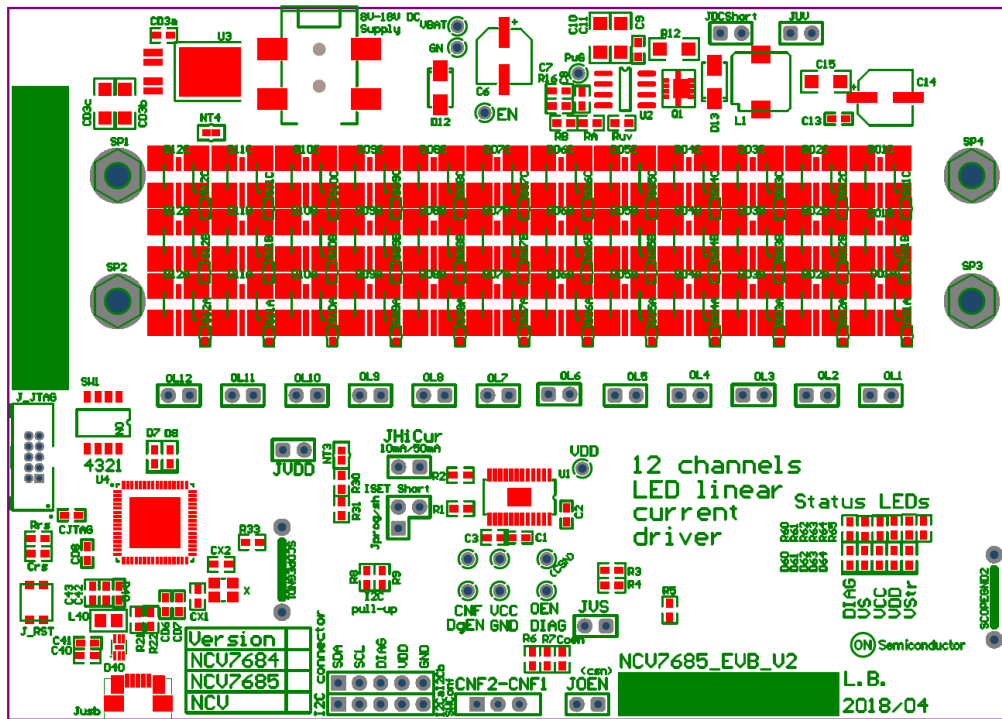

Figure 18. NCV7685 EVB PCB Top Assembly Drawing



Figure 19. NCV7685 EVB PCB Bottom Assembly Drawing

NCV7685I2CV1GEVB

PCB DRAWING - COMPOSITE

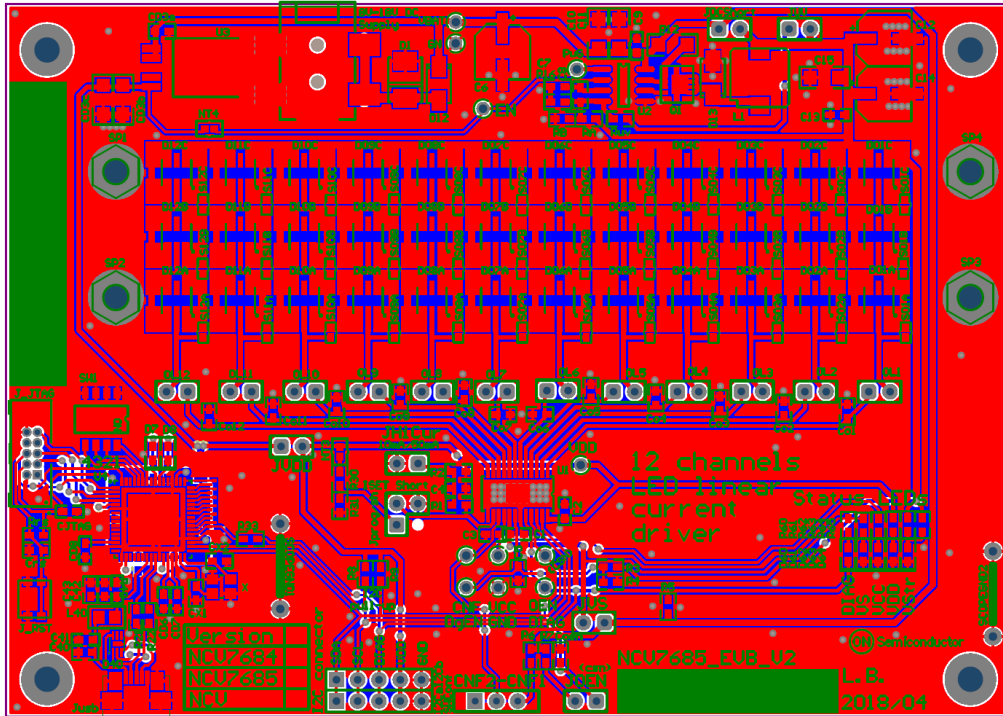

Figure 20. NCV7685 EVB PCB Top Composite Drawing

PCB PREVIEW

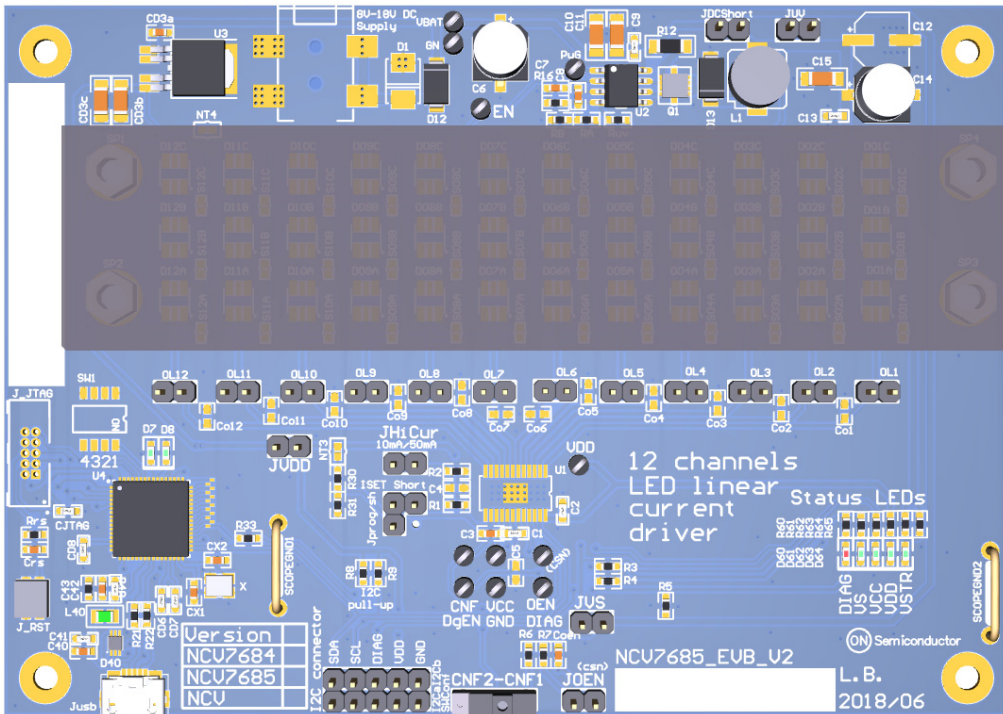

Figure 21. NCV7685 EVB PCB Top Side View

NCV7685I2CV1GEVB

References

- [1] ON Semiconductor, [NCV7685/D](#): 12 Channels 60 mA LED Linear Current Driver I²C Controllable for Automotive Applications, February, 2020 – Rev.1.
- [2] ON Semiconductor, [NCV8853/D](#): Automotive Grade Non-Synchronous Buck Controller, October, 2016 – Rev. 5.
- [3] ON Semiconductor, [AND9764/D](#): NCV7685 I²C Programming Guide, May, 2020 – Rev.2.
- [4] ON Semiconductor, [AND90032/D](#): NCV7685 Driving of the OEN Pin During the VS Startup, March. 2020 – Rev. 0.

onsemi, **Onsemi**, and other names, marks, and brands are registered and/or common law trademarks of Semiconductor Components Industries, LLC dba "**onsemi**" or its affiliates and/or subsidiaries in the United States and/or other countries. **onsemi** owns the rights to a number of patents, trademarks, copyrights, trade secrets, and other intellectual property. A listing of **onsemi**'s product/patent coverage may be accessed at www.onsemi.com/site/pdf/Patent-Marking.pdf. **onsemi** is an Equal Opportunity/Affirmative Action Employer. This literature is subject to all applicable copyright laws and is not for resale in any manner.

The evaluation board/kit (research and development board/kit) (hereinafter the "board") is not a finished product and is not available for sale to consumers. The board is only intended for research, development, demonstration and evaluation purposes and will only be used in laboratory/development areas by persons with an engineering/technical training and familiar with the risks associated with handling electrical/mechanical components, systems and subsystems. This person assumes full responsibility/liability for proper and safe handling. Any other use, resale or redistribution for any other purpose is strictly prohibited.

THE BOARD IS PROVIDED BY ONSEMI TO YOU "AS IS" AND WITHOUT ANY REPRESENTATIONS OR WARRANTIES WHATSOEVER. WITHOUT LIMITING THE FOREGOING, ONSEMI (AND ITS LICENSORS/SUPPLIERS) HEREBY DISCLAIMS ANY AND ALL REPRESENTATIONS AND WARRANTIES IN RELATION TO THE BOARD, ANY MODIFICATIONS, OR THIS AGREEMENT, WHETHER EXPRESS, IMPLIED, STATUTORY OR OTHERWISE, INCLUDING WITHOUT LIMITATION ANY AND ALL REPRESENTATIONS AND WARRANTIES OF MERCHANTABILITY, FITNESS FOR A PARTICULAR PURPOSE, TITLE, NON-INFRINGEMENT, AND THOSE ARISING FROM A COURSE OF DEALING, TRADE USAGE, TRADE CUSTOM OR TRADE PRACTICE.

onsemi reserves the right to make changes without further notice to any board.

You are responsible for determining whether the board will be suitable for your intended use or application or will achieve your intended results. Prior to using or distributing any systems that have been evaluated, designed or tested using the board, you agree to test and validate your design to confirm the functionality for your application. Any technical, applications or design information or advice, quality characterization, reliability data or other services provided by **onsemi** shall not constitute any representation or warranty by **onsemi**, and no additional obligations or liabilities shall arise from **onsemi** having provided such information or services.

onsemi products including the boards are not designed, intended, or authorized for use in life support systems, or any FDA Class 3 medical devices or medical devices with a similar or equivalent classification in a foreign jurisdiction, or any devices intended for implantation in the human body. You agree to indemnify, defend and hold harmless **onsemi**, its directors, officers, employees, representatives, agents, subsidiaries, affiliates, distributors, and assigns, against any and all liabilities, losses, costs, damages, judgments, and expenses, arising out of any claim, demand, investigation, lawsuit, regulatory action or cause of action arising out of or associated with any unauthorized use, even if such claim alleges that **onsemi** was negligent regarding the design or manufacture of any products and/or the board.

This evaluation board/kit does not fall within the scope of the European Union directives regarding electromagnetic compatibility, restricted substances (RoHS), recycling (WEEE), FCC, CE or UL, and may not meet the technical requirements of these or other related directives.

FCC WARNING – This evaluation board/kit is intended for use for engineering development, demonstration, or evaluation purposes only and is not considered by **onsemi** to be a finished end product fit for general consumer use. It may generate, use, or radiate radio frequency energy and has not been tested for compliance with the limits of computing devices pursuant to part 15 of FCC rules, which are designed to provide reasonable protection against radio frequency interference. Operation of this equipment may cause interference with radio communications, in which case the user shall be responsible, at its expense, to take whatever measures may be required to correct this interference.

onsemi does not convey any license under its patent rights nor the rights of others.

LIMITATIONS OF LIABILITY: **onsemi** shall not be liable for any special, consequential, incidental, indirect or punitive damages, including, but not limited to the costs of requalification, delay, loss of profits or goodwill, arising out of or in connection with the board, even if **onsemi** is advised of the possibility of such damages. In no event shall **onsemi**'s aggregate liability from any obligation arising out of or in connection with the board, under any theory of liability, exceed the purchase price paid for the board, if any.

The board is provided to you subject to the license and other terms per **onsemi**'s standard terms and conditions of sale. For more information and documentation, please visit www.onsemi.com.

ADDITIONAL INFORMATION

TECHNICAL PUBLICATIONS:

Technical Library: www.onsemi.com/design/resources/technical-documentation
onsemi Website: www.onsemi.com

ONLINE SUPPORT: www.onsemi.com/support

For additional information, please contact your local Sales Representative at www.onsemi.com/support/sales